

DSP1500T

High-Performance Professional Digitally Steerable Phased Array Column Loudspeaker



Description

The DSP1500T boasts exceptional directional control and enables simultaneous three-axis beam adjustment, delivering an outstanding listening experience for audiences in the target coverage area. Eight custom-designed 4-inch transducers are individually powered by an 8-channel amplifier with an advanced switching power supply, ensuring long-term reliable performance.

Traditional column speakers achieve directivity through fixed physical modifications such as convex, concave, and angled front baffles, offering no post-installation adjustability. In contrast, the DSP1500T phased array column loudspeaker provides flexible remote adjustment of vertical directivity and radiation angles through an intuitive web-based control interface. Its integrated digital equalizer significantly enhances audio clarity and overall sound quality.

Characterized by superior sound reproduction, robust performance, user-friendly operation, and straightforward installation, it is ideally suited for a wide range of professional sound reinforcement applications, effectively minimizing sound energy waste while dramatically improving speech intelligibility.

Features

- Features multiple full-range transducer units with extended frequency response.
- Integrates high-performance DSP with patented sidelobe suppression technology.

- Innovative acoustic design enables projecting the array's acoustic center to up to three distinct audience zones.
- Adjustable vertical directivity precisely directs sound evenly to the target listening area, significantly minimizes upward sound radiation, and reduces unwanted ceiling reflections.
- Digital loudspeaker system with integrated anti-reverberation processing that dramatically enhances speech intelligibility in acoustically challenging environments.
- Intuitive user interface allows visualization and editing of the 3D radiation pattern synthesized by the speaker array.
- Onboard multi-band FIR and IIR equalization for precise audio tuning.
- Supports connection of dedicated passive extension speakers and subwoofers to adapt to diverse application requirements.
- Built-in ultra-sensitive input signal detection for automatic activation and intelligent noise reduction.
- Lightweight aluminum enclosure with compact form factor simplifies transportation and installation.
- Sleek, aesthetic design ideal for speech reinforcement and background music in conference centers, museums, concert halls and similar venues.

Specifications

Model		DSP1500T
Amplifier Frequency	Range	100 – 20kHz
Acoustic Frequency	Range	140 – 12kHz
Maximum SPL	dB	115dB
Coverage	Horizontal (Fixed)	130°
	Vertical (Adjustable)	±45°
	Focus Offset	5 – 50m
Dynamic Range		>100dB
Audio Input	Rated Level	0dBu (line)
	Type (line)	Balanced/Single (1,3GND; 2 Signal)
	Impedance (balanced)	10KΩ
Power Amplifier	Type	PWM (Class D)
	Peak Power (8Ω)	8×25W
Voltage		AC 100V–240V 47- 63Hz
Power Consumption	In Idle	12VA (PFC ≥ 0.92)
	Fully Loaded	400VA (PFC ≥ 0.95)
Ambient temperature		0°C ~ 50°C
Speaker		8×4''
Package Size (mm) (L×W×H)		270×260×1156
Dimensions (mm) (L×W×H)		124.7×139×1024
Gross Weight		15kg
Net Weight		12kg

Front / Rear Panel

Rear Panel

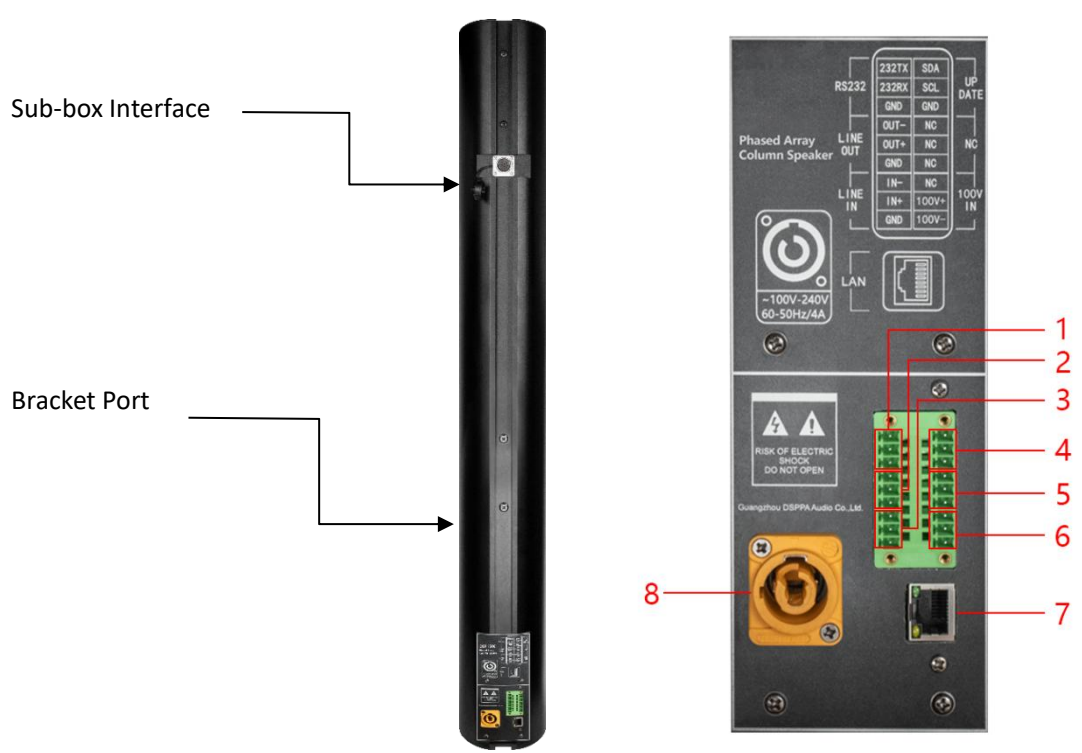

1. RS232 Interface: Connect to the serial port of the computer; The speaker can be controlled by the computer with specific commands.
2. Line Out: Output port of the audio signal (Balanced). It only output the audio signal that is input from the line input port (the size of the output signal has nothing to do with the volume on web control interface).
3. Line Input: Input port of the audio signal (Balanced).
4. System Upgrade Port: For system software upgrade (It is for professional engineers, not for non-professionals).
5. Reserved for Use (no function).
6. Reserved for Use (no function).
7. Ethernet Port: Connect to a computer, logging into Google Chrome to control the column speaker.
8. Power Input Port: AC100V - 240V/60Hz-50Hz.

Directivity Diagram

(1) 30m flat venue, with downward focus length as 6m, 15m, 26.5m and wall mount height 5.5m (Figure 1-1).



SPL Distribution Chart of 3 Preset Positions

Product Dimensions and Mounting Diagram

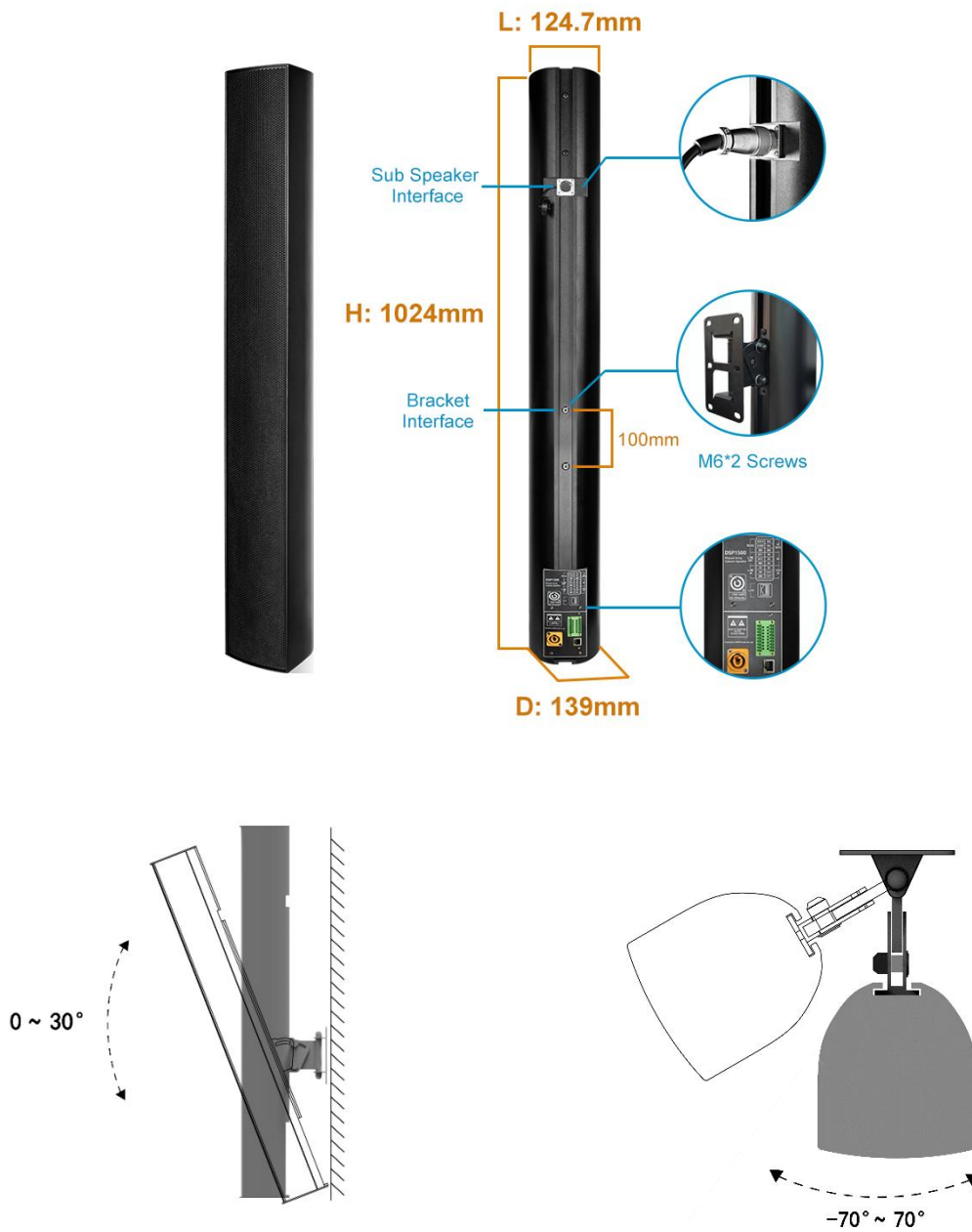

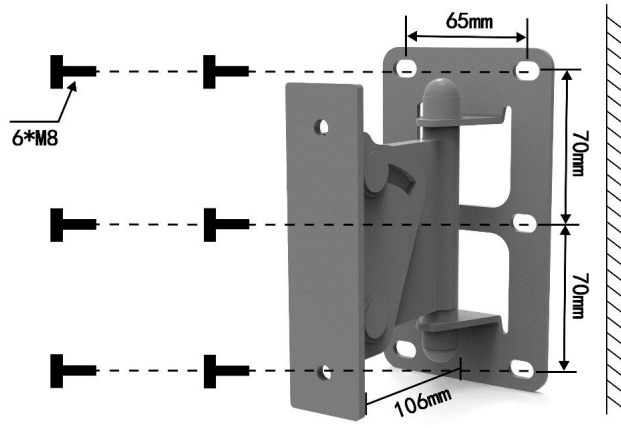

DSP1500T Supporting Bracket Mounting Diagram & Dimensions